

Blanking developments

Part III: High-speed blanking, FE methods

Editor's Note: This is Part III of a three-part series on blanking developments. Part I, which appeared in the July issue, focused on fineblanking and tool design. Part II, which ran in the August issue, covered fineblanking part and process design guidelines.

This column was prepared by Serhat Kaya, of the Center for Precision Forming (CPF, formerly ERC for Net Shape Manufacturing), The Ohio State University, Taylan Altan, professor and director.

During high-speed blanking, press stroking rate and punch speed are higher than in conventional blanking. As a result, the shear zone has a higher strain rate, which affects a workpiece's sheared surface temperature and the tool surface. The heat generated at the highly localized deformation zone doesn't dissipate easily into the workpiece material. This causes a high temperature concentration in the narrow shearing zone.

High Temperatures, Deformation

One of the benefits of high-speed blanking is that temperatures up to 1,800 degrees F (980 degrees C) may be generated in the shearing zone, creating a stress-release effect within the material. Strain hardening, which takes place because of large, localized deformation, can even be neutralized. Because of stress release, the material can withstand a large amount of deformation until shearing strength is exceeded and the material fractures. As a result, deformation-related internal stresses and fractures are dramatically reduced.

However, these advantages are mate-

rial-dependent. For example, heat created from high-speed blanking dissipates faster when cutting copper and aluminum because of their higher thermal conductivity. Ideal high-speed blanking process conditions are achieved when strain hardening is reduced through stress-release effects. This means that the optimum shearing speed has to be large enough so that stress release occurs, but not so large that enough time remains for stress relieving.

These effects improve part edge quality by decreasing the burr height and rollover, and increasing shear zone length (within a certain speed range). Less distortion is created than in blanks produced at low speeds. **Figure 1** illustrates a blanked part's shear zone geometry characteristics.

High-speed blanking experiments were conducted at the CPF at The Ohio State University using low-carbon alloy steel, high-strength steel, copper, and aluminum sheet. These experiments were conducted with an electromagnetic-driven, high-speed Lourdes 100-OH press (see **Figure 2**). This press is controlled through nine power levels that accelerate the tooling to speeds up to 12 feet per second (FPS) (3,655 millimeters per second).

The tooling in **Figure 3** consists of a punch, die button, and polymer strip-

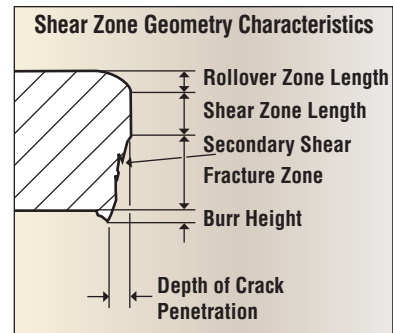

Figure 1

per. All punches and die buttons are made of M-2 high-speed steel and are mounted to the retainers with a ball lock for fast punch and die change. The polymer stripper is mounted directly to the punch and is used for stripping the sheet from the punch after blanking.

Figure 4 illustrates burr height (shown in **Figure 1**) versus the punch-die clearance for different cutting speeds. In the tests, for a cutting speed of 0.5 FPS, the burr height is three to four times higher compared to the 4 FPS, 9 FPS, and 12 FPS cutting speeds. It was also observed that for low-carbon steel, increasing the cutting speed above 4 FPS had no influence on the percentage of shear zone length (ratio of the shear zone length to sheet thickness). **Figure 5** shows the shear zone length as a percentage of sheet thickness and burr height measurements for high-strength steel, aluminum, and copper.

FEA Application

Process simulation using finite element analysis (FEA) offers a practical solution for design and process-related issues in high-speed blanking because the blanking process is fully modeled and

Press Specifications	
Max. Load	10 Tons
Ram Speed	0.50 to 12 FPS (152 to 3,655 mm/s) 9 power levels
Stroke Length	0.5 to 1.5 inch

Figure 2

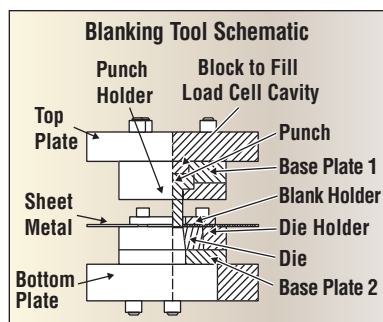

Figure 3

deformation takes place virtually. For simulating the blanking process, the FEM-code DEFORM 2D was used. Simulations were performed with the following settings:

- Low-carbon steel.* Properties from AISI 1015 were taken because they are very close to the properties of the low-carbon steel used. Sheet thickness was 0.033 in.

- Punch-die clearances.* Approximately 5 percent to 18 percent of sheet thickness (punch diameters: 0.488 in. and 0.497 in.; die button: 0.500 in.)

- Punch velocities.* Approximately 0.5 FPS and 12 FPS.

- Nonisothermal condition.* Temperatures increased because deformation was considered.

- Axisymmetric condition.* About half of the geometry was modeled because of symmetry to save computation time.

Figure 6 compares simulation and experiment results for the fracture zone length. The maximum difference was about 7 percent of sheet thickness, which indicates that FEA predicted the deformation of the shear zone reasonably well.

Taylan Altan is a professor and director of the Center for Precision Forming (formerly Engineering Research Center for Net Shape Manufacturing), 339 Baker Systems, 1971 Neil Ave., Columbus, OH 43210-1271, 614-292-9267, www.cpfforming.org. The CPF conducts research and development; educates students; and organizes workshops, tutorials, and conferences for the industry in stamping, tube hydro-forming, forging, and machining.

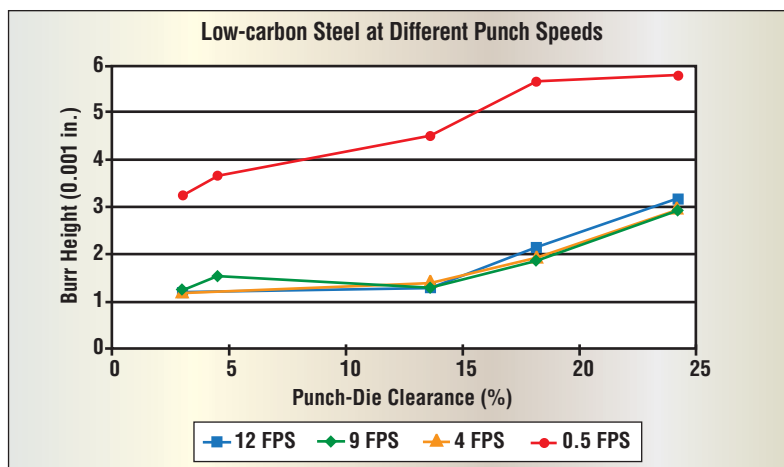

Figure 4

Source: M. Gruenbaum, J. Breitting, T. Altan, "Influence of High Cutting Speeds on the Quality of Blanked Parts," Report No. ERC/NSM-S-96-19, Engineering Research Center for Net Shape Manufacturing, The Ohio State University, 1996.

Burr Height, Shear Zone Length			
	Cutting Speed (FPS)	Shear Zone Length (%)	Burr Height (0.001 in.)
High-strength Steel (50-XF) (Thickness = 0.054")	0.5	40	1.8
	12	56	1.8
Aluminum (2011-T3) (Thickness = 0.041")	0.5	46	0.7
	12	46	0.75
Copper (110) (Thickness = 0.016")	0.5	70	0.6
	12	90	0.6

Figure 5

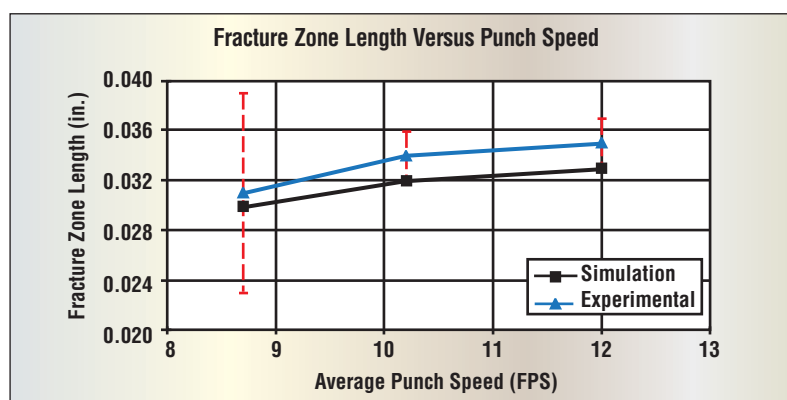

Figure 6

Source: O. Yildirim, I. Al-Zkeri, T. Altan, "Determination of Critical Damage Value at High Strain Rate for AISI 1050 Using a Blanking Process," results of experimental and numerical investigations, ERC/NSM Report No. HPM/ERC/NSM-03-R-11, The Ohio State University, 2003.